

**SONY®**

**REPLAY**

# LV-1901

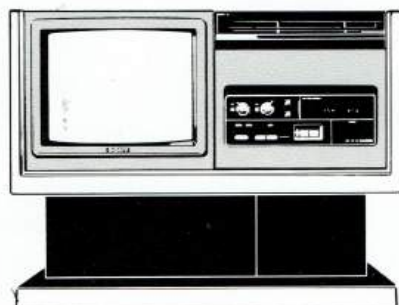

**Operating instructions**

The LV-1901 is a product of advanced Sony Trinitron TV and VTR technology, and is designed for ease of operation. To familiarize yourself with all the features and capabilities of the LV-1901, read this manual completely and keep it handy for future reference.

## CONTENTS

FEATURES .....	3
IMPORTANT POINTS TO REMEMBER .....	3
LOCATION OF CONTROLS .....	4
NORMAL TV VIEWING .....	6
RECORDING TV PROGRAMS .....	8
Rewind and Fast Forward	
Pause	
Tape Counter and COUNTER MEMORY Switch	
Safety Tab	
PLAYBACK .....	10
Tracking Adjustment	
RECORDING ONE TV PROGRAM WHILE	
VIEWING ANOTHER .....	11
TIMER RECORDING .....	12
CAMERA RECORDING .....	14
ERASING .....	15
CLEANING THE VIDEO HEADS .....	15
THE STAND BY LAMP .....	15
CHECKING THE SET .....	16
TECHNICAL SPECIFICATIONS .....	18

The operating instructions and the ready-reference cards may be conveniently stored in the base.

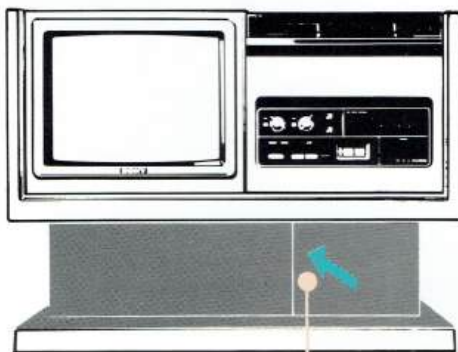

To open, push in the door;  
to close, push in again.

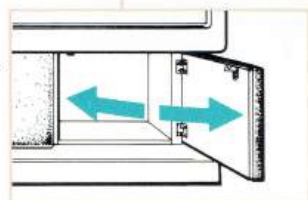

## WARNING

Dangerously high voltages are present inside the set. **DO NOT OPEN THE CABINET.** Refer servicing to qualified personnel.

To prevent fire or shock hazard, do not expose the set to rain or moisture.

## NOTE

Purchase of the LV-1901 includes normal equipment adjustment and connection to an existing antenna. If your present antenna system is inadequate to produce optimum results, optional equipment may be required. Consult your Sony dealer for additional information about antenna connections.

## FEATURES

- Ease of operation

The LV-1901 is as easy to operate as a TV set and an audio cassette tape recorder.

- Normal TV viewing

As a TV set, the LV-1901 receives VHF and UHF channels.

- Record color or black-and-white programs

The VHF and UHF tuners supply TV signals for recording on the Betamax recorder. Additional VHF and UHF tuners permit recording one TV program while viewing another.

- Playback

The picture and sound of a recorded videocassette may be played on the LV-1901 TV.

- Timer recording

With the aid of the built-in timer, TV programs may be recorded while the LV-1901 is unattended.

- Line recording

Line recording is possible by connecting a television camera and a microphone to the recorder.

- ECONOQUICK system

The LV-1901 contains Sony's unique ECONOQUICK feature, which provides a picture within a few seconds after the TV POWER Button is pressed. Unlike conventional instant-picture systems, there is no power consumed by the picture tube when the LV-1901 is not in use.

## IMPORTANT POINTS TO REMEMBER

- Operate the set only on 120 V ac, 60 Hz.

- Should any liquid or solid object fall into the cabinet, unplug the set and have it checked by qualified personnel before operating it any further.

- Allow sufficient room behind the set (more than 3 inches) to prevent internal heat build-up. Do not place the set near materials (curtains, draperies) that may block the ventilation holes.

- Do not attempt to make any of the adjustments at the small holes in the rear of the set. These are special adjustments to be performed only by service personnel.

- To disconnect the cord, pull it out by the plug. Never pull the cord itself.

- Do not install the set in a location near heat sources such as radiators or air ducts, or in a place subject to direct sunlight, excessive dust, mechanical vibration or shock.

- Keep the set and the videocassette away from strong magnetic fields.

- The set is equipped with casters. Avoid subjecting the set to unnecessary shock or impact particularly when moving it.

- After playing a tape, remove the cassette from the compartment if the set will not be used for any length of time.

Do not transport the set with a videocassette in place.

# LOCATION OF CONTROLS

## TV/Timer Section

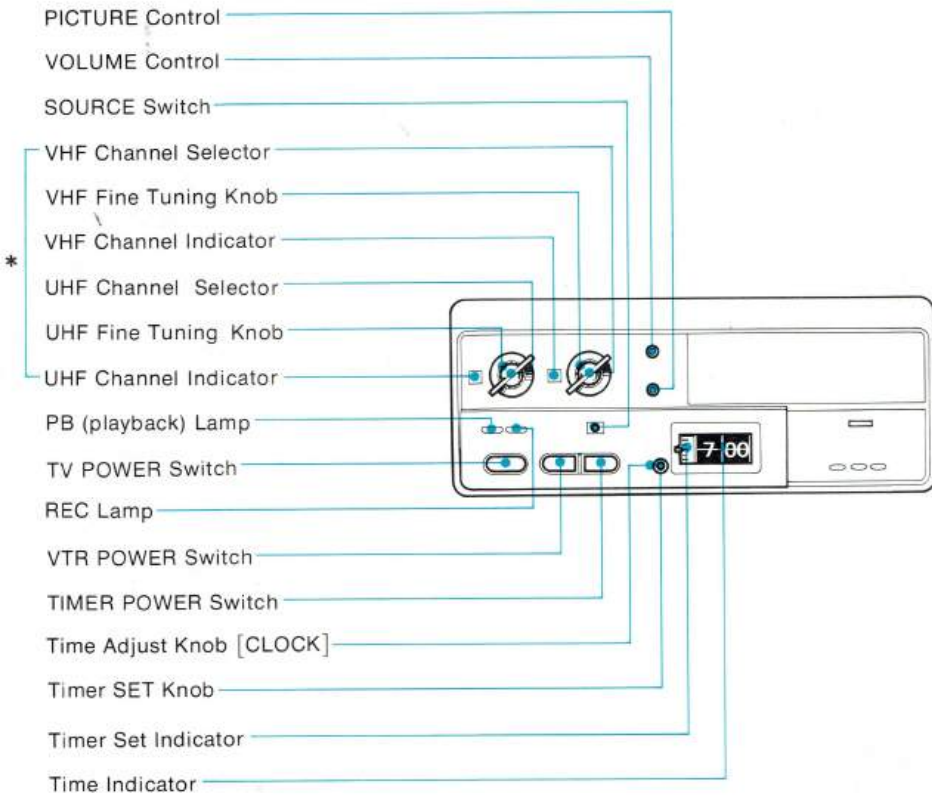

## \* Main Tuner Controls

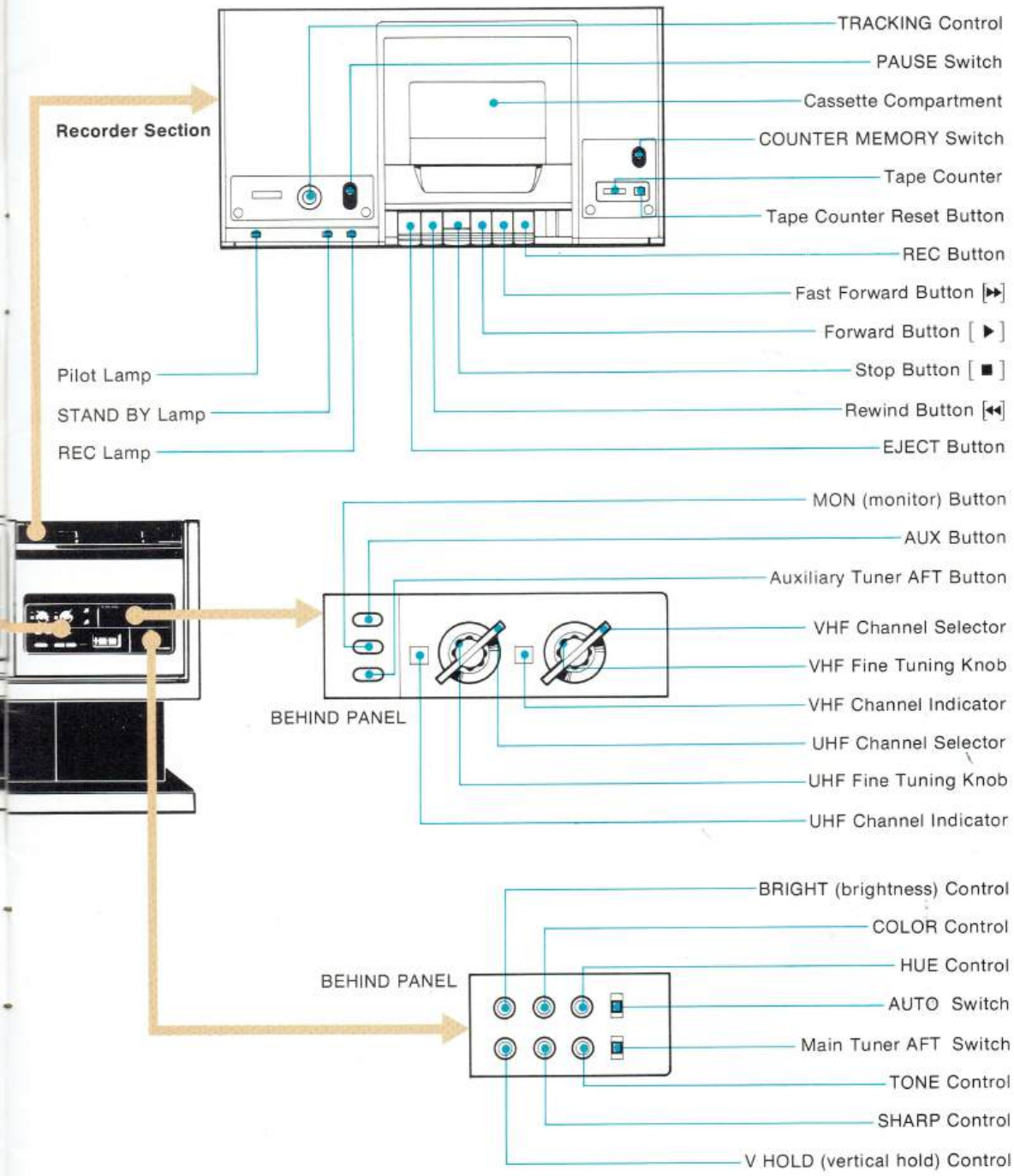

## NORMAL TV VIEWING

Circled numbers refer to step numbers in the text.

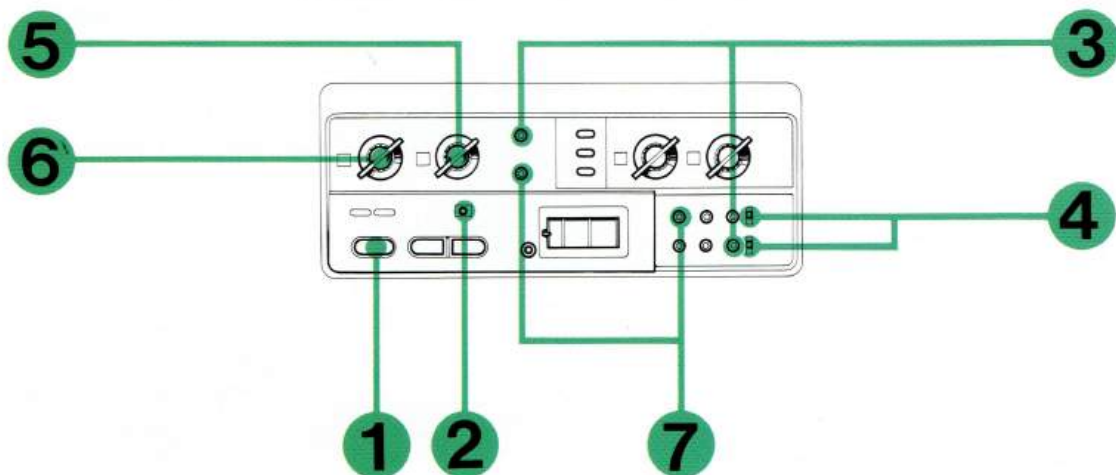
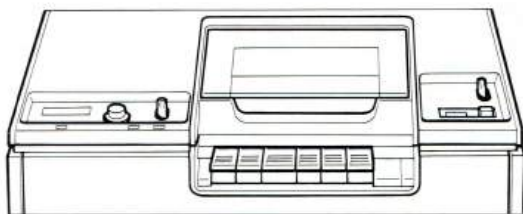

Connect the power cord to an ac wall outlet.

1 Push the TV POWER Button to switch on the TV. The button will light in green.

2 Set the SOURCE Switch to TV.

3 Adjust the VOLUME Control. To increase the sound, turn clockwise; to decrease, turn counterclockwise. Adjust the TONE Control for desired tone quality. For increased treble, turn clockwise; for less treble, turn counterclockwise.

4 Set the AUTO and Main Tuner AFT Switches to ON to operate in the automatic mode.

- In the automatic mode, the AFT (Automatic Fine Tuning) locks in the correct signal and secures sharper pictures on all channels.

- The AUTO Switch locks the color circuits to preset values of hue and color to provide correct reproduction.

5 To select the desired VHF channels (2-13), turn the Main Tuner VHF Channel Selector until the desired channel number appears in the Indicator. After initial

adjustment there will be no need for fine tuning adjustments on the VHF channels. However, if the picture is not clear, adjust the fine tuning as follows: Push in the VHF Fine Tuning Knob and turn it clockwise until a herringbone pattern appears in the colored parts of the picture.

Then turn the knob slowly counterclockwise and release it at the point where the herringbone pattern just disappears and the picture is clear. This is the correct tuning point.

(See photos on the next page.)

- When the VHF fine tuning adjustment is made for the first time, it may be necessary to turn the Fine Tuning Knob several rotations. Subsequent corrections will require a smaller degree of adjustment.

- In the automatic mode, when the Fine Tuning Knob is pushed in, the AFT is disengaged in order to permit manual fine-tuning. When the knob is released, the AFT will be reactivated to maintain correct tuning.



VHF Fine Tuning Knob



VHF Fine Tuning Knob



6 To select the desired UHF channel (14–83) : Turn the VHF Channel Selector until the letter U shows in the Indicator. Then turn the UHF Channel Selector until the desired channel appears. In cases of extreme interference or extremely weak stations, adjust the fine tuning as follows.

- ① Set the Main Tuner AFT Switch to OFF to release the automatic fine tuning.
- ② Slowly turn the UHF Fine Tuning Knob clockwise until a herringbone pattern appears in the colored parts of the picture. Then slowly turn the knob counterclockwise until the herringbone pattern just disappears and the picture is clear.
- ③ Set the AFT Switch to ON to reactivate the automatic fine tuning.

7 Adjust brightness and contrast.

Correct brightness and contrast settings are very important for good color reproduction. Once the brightness has been set correctly, the contrast can be controlled with the PICTURE Control without altering the color reproduction.

Perform the following adjustments.

- ① Turn the PICTURE Control fully counterclockwise.
- ② Adjust the BRIGHT Control for the desired brightness level.
- ③ Adjust the PICTURE Control from the lowest setting to the desired level to suit preference and room lighting conditions.

The PICTURE Control will adjust the contrast, color intensity and brightness simultaneously in the proper ratio.

**To adjust sharpness**

Turn the SHARP Control clockwise for maximum sharpness. Turn the control counterclockwise for a softer picture. If reception conditions cause a snowy picture, more pleasing results will be obtained with a softer picture.

**Vertical hold control**

If the picture rolls vertically, adjust the V HOLD Control.

**Earphone jacks**

For private listening, insert the earphone plug in the [ - ] receptacle. This disconnects the speaker. Use of the [ •• ] receptacle permits the earphone and the speaker to be used simultaneously.

**To adjust color and hue manually**

Both COLOR and HUE Controls have a limited adjustment range in the AUTO mode. This permits slight alterations of color values to suit personal preference. If you wish to control color reproduction manually, set the AUTO Switch to OFF to release the automatic color mode.

Adjust the COLOR Control for the desired color intensity.



Picture becomes pale.



Picture becomes vivid.



Adjust the HUE Control for the most natural skin tones.



Skin tones become purple.



Skin tones become green.



• COLOR and HUE adjustments have no effect upon black and white programs.

## RECORDING TV PROGRAMS

Circled numbers refer to step numbers in the text.

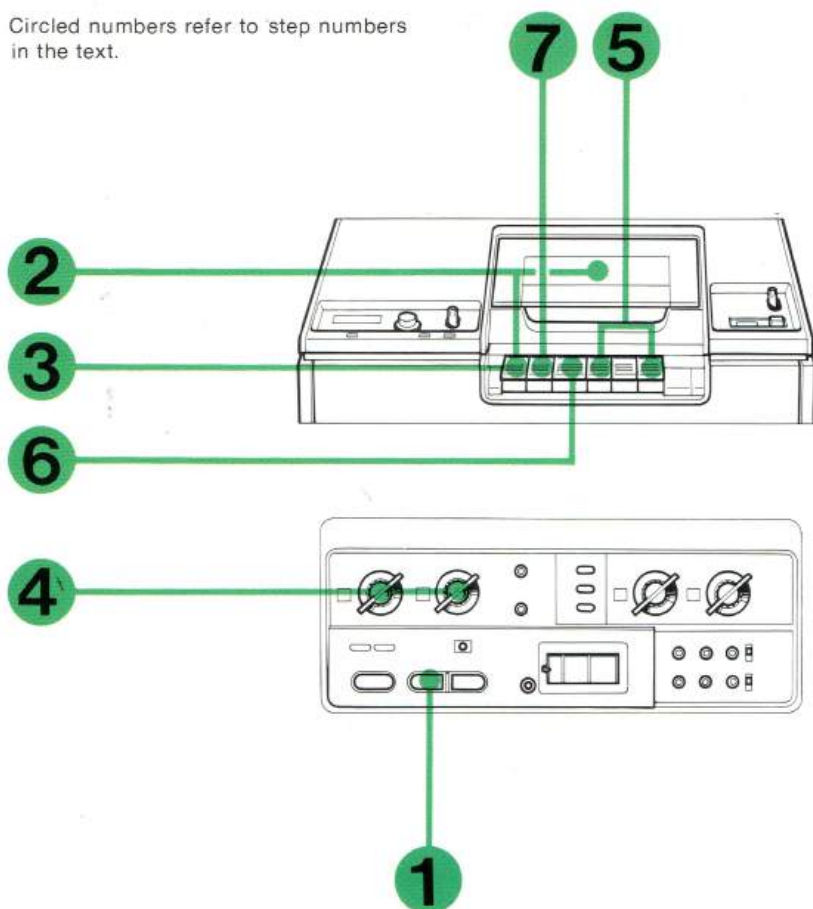

Before proceeding, turn on the TV, set the SOURCE Switch to TV and make all necessary adjustments on the TV to obtain the best possible picture.

① Press the VTR POWER Button to switch on the recorder. The button will light in green.

② Inspect the bottom of the videocassette on which the recording is to be made. Make sure that the Safety Tab has not been removed. Recordings cannot be made if the tab has been removed. (See "Safety Tab"

on page 9.)

③ Press the EJECT Button and insert the videocassette as illustrated. Slide the videocassette in as far as it will go.

Push down the Cassette Compartment into the play position.

The amber STAND BY Lamp will light. After a few seconds, the lamp will go out signaling the completion of the tape threading cycle.

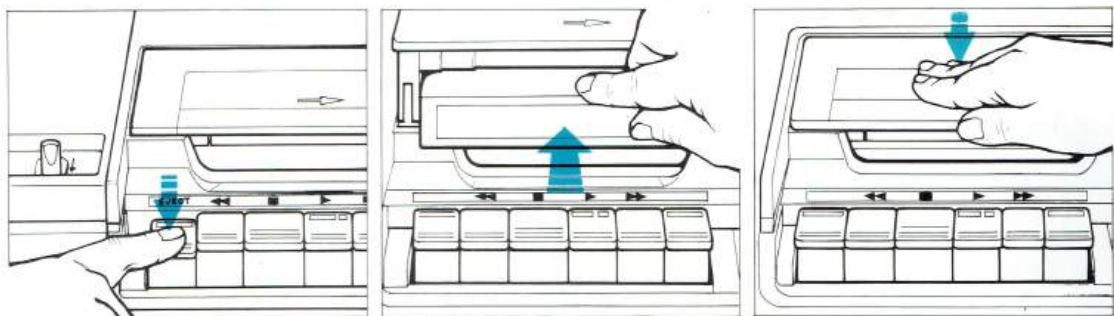



- 4 Select the TV program to be recorded using the Main Tuner VHF or UHF Channel Selector.
- 5 Hold down the REC Button and depress the Forward Button [▶]. The REC Lamp will light and the recording will begin.
- 6 At the end of the recording, press the Stop Button [■].
- 7 Rewind the tape by pressing the Rewind Button [◀◀]. When the tape has reached its end, it will stop automatically and the Rewind Button [◀◀] will be released.
- 8 Press the EJECT Button. The amber STAND BY Lamp will light. After a few seconds, the lamp will go out signaling the completion of the unthreading cycle and the Cassette Compartment will eject automatically. Remove the videocassette and press down the Cassette Compartment.

### Operating notes

- Remember to go to Stop [■] when changing functions. For example, to go from Play to Rewind, it is necessary to first press Stop [■] and then press Rewind [◀◀].
- If the tape is fully rewound, and the Rewind [◀◀] Button is pressed, the machine will continue to run in the rewind mode. In this case, press the Stop [■] Button before proceeding with the desired mode of operation.
- To monitor the recording signal, press the MON Button. The button will light in amber. To watch a telecast TV program, push the MON Button again.

### Caution

Television programs, films, video tapes and other materials may be copyrighted. Unauthorized recording of such material may be contrary to the provisions of United States copyright laws.

### Rewind and Fast Forward

Rewind and fast forward may be selected after the machine has been placed in the stop mode. When the tape has reached the end of the rewind or fast-forward operation, the tape stops automatically and the Rewind [◀◀] or Fast Forward [▶▶] Button will be released. The tape may be stopped at any point during rewind or fast forward by pressing the Stop [■] Button.

### Pause

The PAUSE Switch stops the tape momentarily in either record or playback.

- 1 To stop the tape momentarily during playback, slide the PAUSE Switch toward you. To restart the tape, return the PAUSE Switch.
- 2 To start recording from pause, slide the PAUSE Switch toward you, press the REC Button, and then return the PAUSE Switch. Recording will begin immediately.
- 3 To stop the tape after pause, press the Stop [■] Button.
  - Use the Stop [■] Button for extended pause operation, particularly if for longer than about ten minutes.

### Tape Counter and COUNTER MEMORY Switch

#### Tape Counter

Reset the Tape Counter before initiating a recording for later reference in playback.

#### COUNTER MEMORY Switch

The COUNTER MEMORY Switch is used for precise program relocation in the recorded tape.

- 1 Locate any desired starting point and reset the Tape Counter to register this point ("000" shown in the counter).
- 2 Set the COUNTER MEMORY Switch to ON.
- 3 Play or record the tape.

- 4 Press the Rewind [◀◀] Button.

The tape motion will stop and the selected button will be released automatically at the Tape Counter reading "999" (one count before "000" in order to avoid missing the starting point).

- To rewind the tape further than the "000" point, depress the Rewind [◀◀] Button again.

### Safety Tab

To protect a recording from accidental erasure, break off the tab on the bottom of the videocassette using a screwdriver or similar device. With the tab removed, the REC Button cannot be depressed. If you wish to record on a cassette with the tab removed, simply cover a hole with a piece of cellophane or vinyl tape.

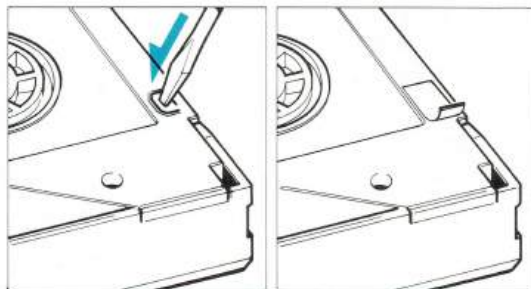
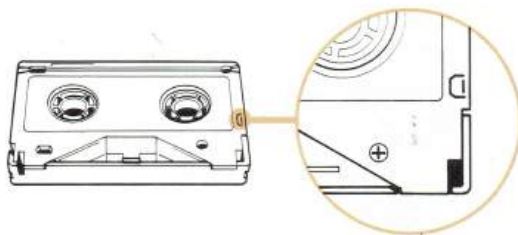

## PLAYBACK

Circled numbers refer to step numbers in the text.

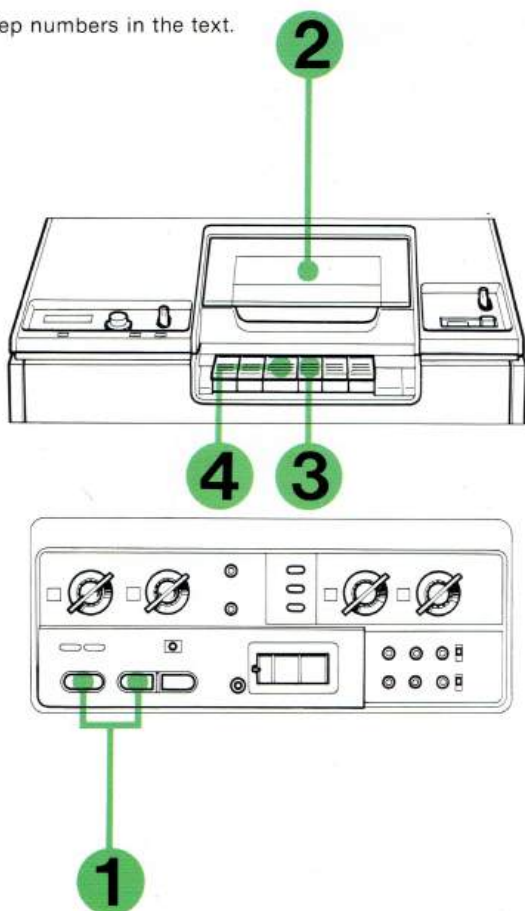

1 Press the TV POWER and VTR POWER Buttons.

2 Insert the videocassette into the recorder as previously described in "RECORDING TV PROGRAMS". Wait until the amber STAND BY Lamp goes out.

3 Press the Forward [ ► ] Button. The green PB Lamp will light.

4 To stop the tape, press the Stop [ ■ ] Button.

- After use, turn off the TV POWER and VTR POWER Buttons. Keep the ac cord plugged in so that the timer is always powered.

- Since the full width of the tape is used for recording pictures and sound, the tape cannot be reversed.

### Tracking Adjustment

In the unlikely event that streaks of snow appear in the playback of tapes made on other recorders, turn the TRACKING Control in either direction until the best picture is obtained. Allow a second or two for new settings to take effect. When playback of this particular tape is finished, return the TRACKING Control to its center detent position.

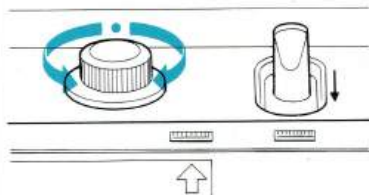

## RECORDING ONE TV PROGRAM WHILE VIEWING ANOTHER

Circled numbers refer to step numbers in the text.

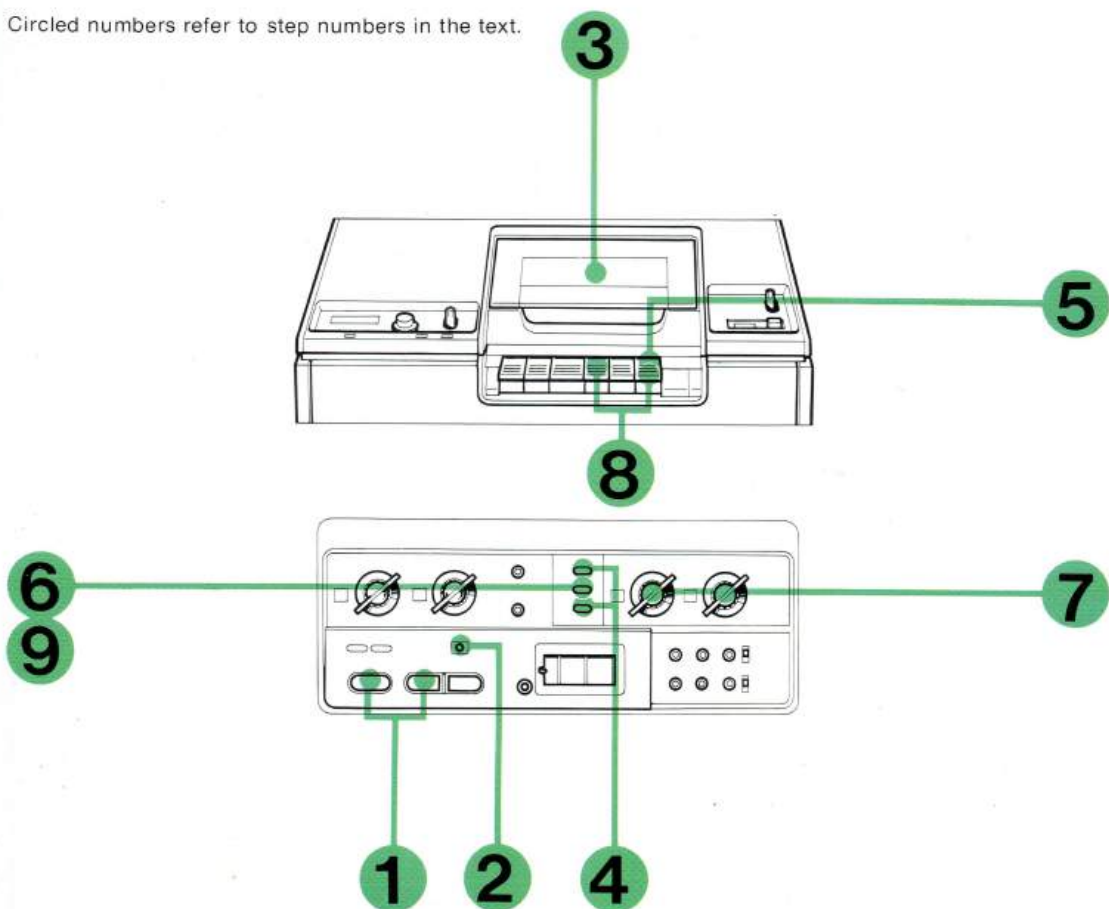

- 1 Press the TV POWER and VTR POWER Buttons.
- 2 Set the SOURCE Switch to TV.
- 3 Insert the videocassette into the recorder. (Check that the Safety Tab at the bottom of the cassette has not been removed.)
- 4 Press the AUX Button. The button will light in amber to indicate that the TV signals from the Auxiliary Tuner are being supplied to the recorder. Press the Auxiliary Tuner AFT Button. The button will light indicating the automatic fine tuning mode.
- 5 Press the REC Button.
- 6 Press the MON Button to monitor the picture to be recorded. The button will light in amber.
- 7 Select the TV program to be recorded using the Auxiliary Tuner VHF or UHF Channel Selector. Adjust the Auxiliary Tuner Fine Tuning Knob for the best picture. The adjustment procedure is the same as that of the Main Tuner Fine Tuning Knob.
- 8 Hold down the REC Button and depress the Forward [▶] Button. The red REC Lamp will light and the recording will begin. Automatic gain control circuits

in the LV-1901 maintain all recording levels at optimum values.

- Press the MON Button again to display the Main Tuner signals on the screen (the button light will go out). Thus you can record a TV program from the Auxiliary Tuner while viewing another program on the Main Tuner.

## TIMER RECORDING

### Time Adjustment

- ① Turn the Time Adjust [CLOCK] Knob clockwise until the Time Indicator reads one minute before the hour (for example, "AM 6 : 59").
- ② Plug the AC Power Cord into a wall outlet.
- ③ Remove the power cord from the wall outlet when the Time Indicator reaches the exact hour (for example, "AM 7 : 00").
- ④ Reconnect the power cord simultaneously with a standard time signal (broadcast, telecast or telephone) of the appropriate hour. The Time Indicator will light when the timer is powered.

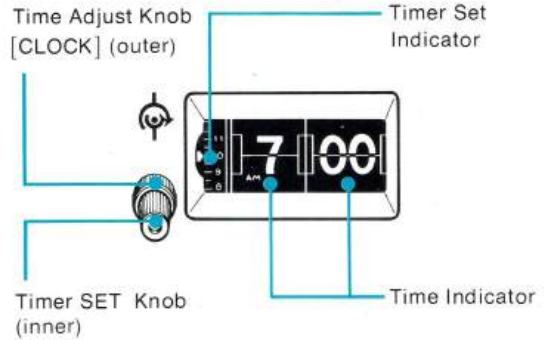

Circled numbers refer to step numbers in the text.

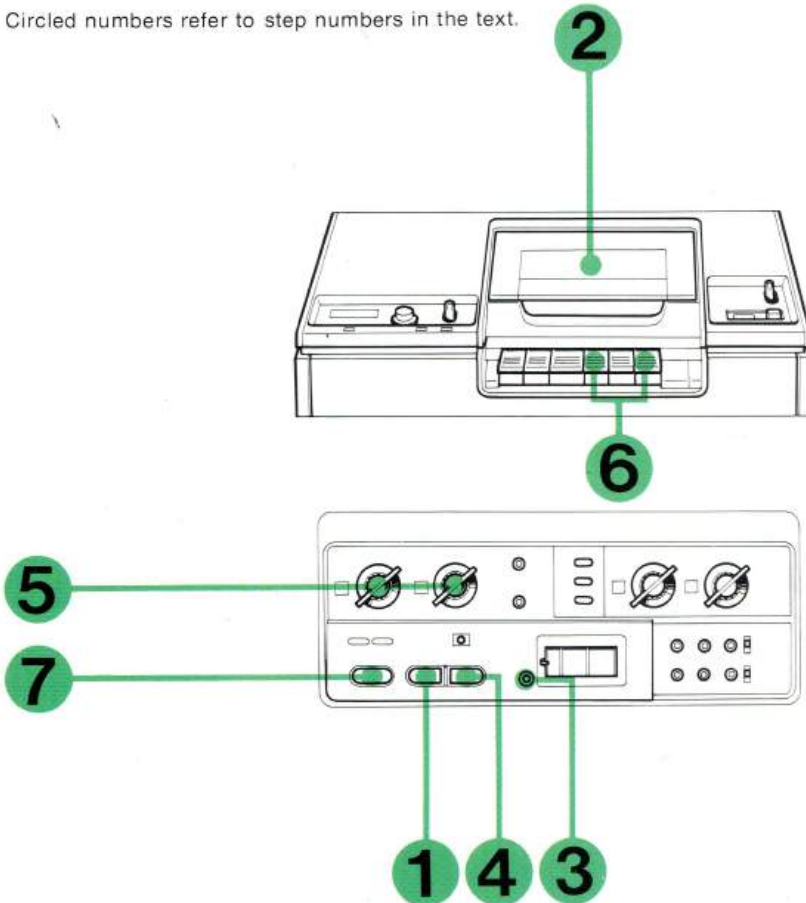

## Timer Recording

Before proceeding, turn on TV, set the SOURCE Switch to TV and make all necessary adjustments on the TV for the best possible picture. Be sure to follow this procedure in the sequence given (steps 4 and 6 cannot be reversed).

- 1 Press the VTR POWER Button. The VTR button will light.
- 2 Insert the videocassette into the recorder. Be sure that the Safety Tab at the bottom of the cassette has not been removed.
- 3 Set the turn-on time on the Timer Set Indicator drum to the red arrow by turning the Timer SET Knob (inner knob) counterclockwise. The drum is graduated in ten minutes intervals with click-stops at every interval.
- 4 Press the TIMER POWER Button. The TIMER button will light in amber and the VTR lamp will go out indicating that power to the recorder has been turned off.
- 5 Select the TV program to be recorded.
- 6 Hold down the REC Button and depress the Forward [ ▶ ] Button.
- 7 Turn off the TV POWER Button. The recorder will turn on and start recording at the preset time.
  - To monitor the recording signal, press the MON Button. To watch a telecast TV program, push the MON Button again.
  - After the tape has run out, the recorder will shut off automatically. The timer will shut off about 90 minutes after the preset time.
  - A timer camera recording may be made as described above by setting the SOURCE Switch to CAMERA and presetting the equipment as described in the next paragraph.
  - A timer recording of one TV program from the Auxiliary Tuner while viewing another on the Main Tuner may be accomplished by pressing the AUX Button before initiating the recording. To do this, release the TIMER POWER Button and preset Auxiliary Tuner controls as described in "RECORDING ONE TV PROGRAM WHILE VIEWING ANOTHER". Then reactivate the TIMER POWER Button.

## CAMERA RECORDING

Circled numbers refer to step numbers in the text.

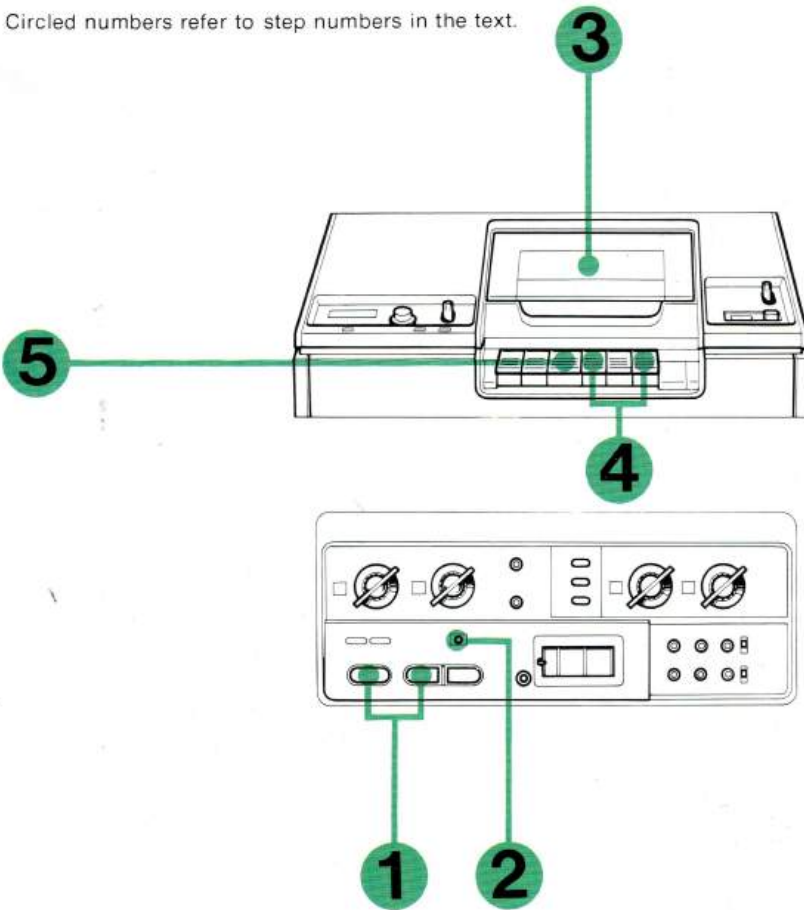

Set up the system as shown in the illustration.  
Cameras must conform to American TV Standards  
using EIA or industrial sync.

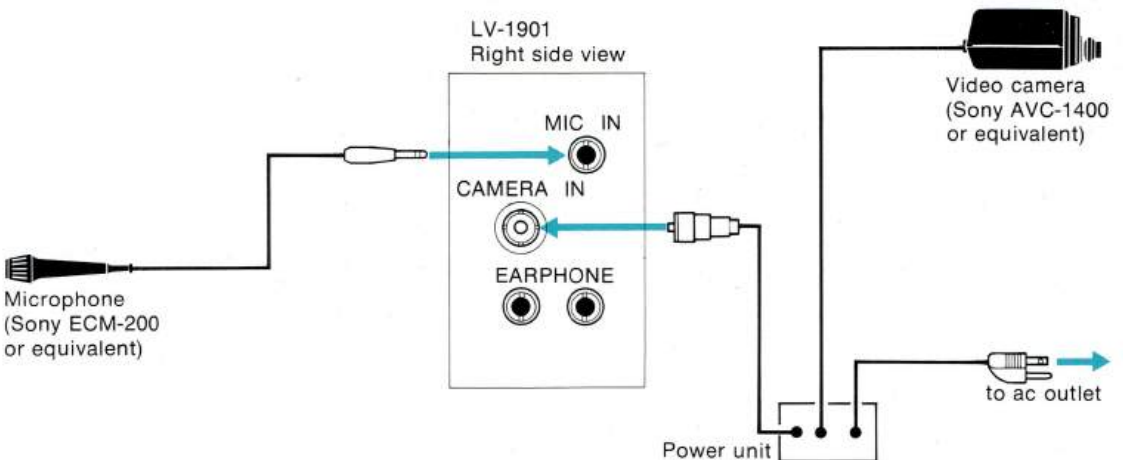

- 1 Press the TV POWER and VTR POWER Buttons. Be sure that the AUX Button is OFF (not lit).
- 2 Set the SOURCE Switch to CAMERA. The TV screen display the camera signal. Make all necessary camera adjustments in readiness for recording.
- 3 Insert a videocassette into the recorder. (Check that the Safety Tab at the bottom of the cassette has not been removed).
- 4 After the STAND BY Lamp goes out, hold down the REC Button and depress the Forward [▶] Button.
- 5 At the end of the recording, press the Stop [■] Button.

- If the microphone is too near a speaker, acoustic feedback (whistle-like sound) may occur. In this case, move the microphone away from the speaker of the LV-1901 or turn down the VOLUME Control.
- If the picture does not appear on the screen, check that the AUX Button is OFF (not lit). The Auxiliary Tuner has the priority over the camera in the picture displayed on the screen.
- To monitor the recording signal, press the MON Button.

## ERASING

The erase head is energized in the record mode. Whenever a new recording is made, the previous recording on the tape is erased. Should you desire to erase a section of tape without recording, proceed as follows.

- 1 Disconnect all signal sources.
- 2 Set the SOURCE Switch to CAMERA. Check that the AUX Button is OFF (not lit).
- 3 Run the tape in the record mode.

## CLEANING THE VIDEO HEADS

The appearance of snow or streaks playback may indicate the need for cleaning the video heads inside the recorder. Should the need for head cleaning be suspected, consult your dealer or local Sony authorized service station.



## THE STAND BY LAMP

The STAND BY Lamp functions in the following three ways.

1. When the videocassette is inserted and the compartment is pressed down into the play position, the STAND BY Lamp will light for the few seconds that it takes for the tape to thread. When the lamp goes out, threading is complete and the machine is ready for operation.

When the EJECT Button is pressed after operation, the lamp will light for the few seconds that it takes for the tape to unthread back into the cassette. When the lamp goes out, unthreading is complete and the cassette may be removed.

2. If you transport the set directly from a cold location to a warm location, moisture may condense inside the recorder. To prevent possible damage under this condition, the STAND BY Lamp will light indicating that excessive moisture has been detected within the recorder. If the lamp lights, keep the recorder power ON and wait until the lamp goes off. If the lamp should stay on for several hours, consult your dealer or local Sony authorized service station for advice.







3. The LV-1901 features a tape slack sensor that protects the recorder and videocassette tapes from being damaged due to faulty tape movement. The machine will automatically revert from the Forward mode to the Stop mode.

Should this condition occur, switch off power and consult your dealer or local Sony authorized service station.

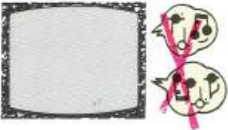
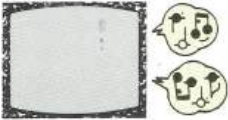
## CHECKING THE SET

Apparent malfunctions may be caused by slight misadjustment of the controls or other simple cause. Should any difficulty arise in the operation of the set,

check through this illustrated list of symptoms and corrections. Should the difficulty persist, unplug the set and contact your dealer.

SYMPTOM	POSSIBLE CAUSE
 <ul style="list-style-type: none"> <li>• no picture (screen not lit), no sound</li> </ul>	<ul style="list-style-type: none"> <li>• Is the set plugged into a working outlet?</li> <li>• Is the TV POWER Button depressed?</li> <li>• Is the SOURCE Switch set to TV?</li> </ul>
 <ul style="list-style-type: none"> <li>• no picture (screen not lit), but good sound</li> </ul>	<ul style="list-style-type: none"> <li>• Turn the BRIGHT or PICTURE Control clockwise.</li> </ul>
 <ul style="list-style-type: none"> <li>• good picture but no sound</li> </ul>	<ul style="list-style-type: none"> <li>• Turn the VOLUME Control clockwise.</li> <li>• Check that the earphone is not plugged into the [·] earphone jack.</li> </ul>
 <ul style="list-style-type: none"> <li>• no color</li> </ul>	<ul style="list-style-type: none"> <li>• Check that the AUTO and AFT Switches are set to ON.</li> <li>• Turn the COLOR Control clockwise.</li> <li>• Readjust the fine tuning.</li> </ul>
 <ul style="list-style-type: none"> <li>• no color, no picture, poor sharpness, herringbone pattern, stripes, etc.</li> </ul>	<ul style="list-style-type: none"> <li>• Readjust the fine tuning.</li> </ul>
 <ul style="list-style-type: none"> <li>• dotted lines or stripes</li> </ul>	<ul style="list-style-type: none"> <li>• Often caused by interference from autos, neon signs, hair dryers, electric razors, etc. Adjust the antenna for minimum interference.</li> </ul>
 <ul style="list-style-type: none"> <li>• double images</li> </ul>	<ul style="list-style-type: none"> <li>• Usually caused by reflections from nearby mountains or buildings. A highly-directional external antenna may improve the picture.</li> </ul>
 <ul style="list-style-type: none"> <li>• snow or streaks in the playback picture</li> </ul>	<ul style="list-style-type: none"> <li>• Adjust the TRACKING Control.</li> <li>• Video-head cleaning may be required. Consult Sony service personnel.</li> </ul>



SYMPTOM	POSSIBLE CAUSE
<ul style="list-style-type: none"> <li>• The REC Button cannot be depressed.</li> </ul>	<ul style="list-style-type: none"> <li>• Check that the Safety Tab has not been removed from the cassette.</li> </ul>
<ul style="list-style-type: none"> <li>• The Forward [ ► ] Button cannot be depressed.</li> </ul>	<ul style="list-style-type: none"> <li>• Insert the videocassette.</li> </ul>
<ul style="list-style-type: none"> <li>• The tape does not move.</li> </ul>	<ul style="list-style-type: none"> <li>• Check that the PAUSE Switch is returned.</li> </ul>
<ul style="list-style-type: none"> <li>• The machine stops in rewind before the end of the tape.</li> </ul>	<ul style="list-style-type: none"> <li>• Set the COUNTER MEMORY Switch to OFF.</li> </ul>
<ul style="list-style-type: none"> <li>• Rewind, forward or fast-forward operation does not function.</li> <li>• The STAND BY Lamp does not extinguish.</li> </ul>	<ul style="list-style-type: none"> <li>• Check that the tape is not at the either end.</li> <li>• See "THE STAND BY LAMP" on page 15.</li> </ul>
<ul style="list-style-type: none"> <li>• Camera/Mic recording cannot be made.</li> </ul>	<ul style="list-style-type: none"> <li>• Check equipment connections.</li> <li>• Is the camera switched on?</li> <li>• Check that the SOURCE Switch is set to CAMERA.</li> <li>• Check that the AUX Button is not lit.</li> </ul>
<ul style="list-style-type: none"> <li>• Timer recordings cannot be made.</li> </ul>	<ul style="list-style-type: none"> <li>• Check that the TIMER POWER Button is lit.</li> <li>• Check the position of the SOURCE Switch.</li> </ul>

## TECHNICAL SPECIFICATIONS

### General

Power requirements	120 V ac, 60 Hz
Power consumption	270 W (max)
Operating temperature	41 °F – 104 °F
Weight	288 lb 2 oz
Dimensions	43 <sup>3</sup> / <sub>4</sub> " × 33 <sup>1</sup> / <sub>2</sub> " × 21 <sup>3</sup> / <sub>8</sub> " (w/h/d)
Accessories supplied	Earphone External Antenna Connector EAC-22 (300-ohm to 75-ohm matching transformer) 75-ohm coaxial cables (2) VHF Antenna Splitter Betamax Videocassette Tapes (2)

### TV section

Television system	American TV standards
Channel coverage	VHF channels 2–13 UHF channels 14–83
Picture tube	Trinitron tube 19" measured diagonally 114-degree deflection
Antenna	75-ohm external antenna terminals for VHF 300-ohm external antenna terminals for VHF and UHF
Semiconductors	2 FETs, 1 GCS, 12 ICs, 88 transistors, 61 diodes
Speakers	6 <sup>1</sup> / <sub>4</sub> " dia, 2 <sup>3</sup> / <sub>4</sub> " dia

### Recorder section

Video recording system	Rotary two-head helical scan system luminance: FM recording color signal: converted subcarrier direct recording
Video signal system	EIA standard, NTSC color signals
Video input	CAMERA IN connector, 1 V ± 0.1 V (p-p), 75-ohms, unbalanced
Audio input	MIC IN connector, –60 dBs, suitable for microphones with 600-ohm impedance
Horizontal resolution	monochrome: more than 280 lines color: more than 240 lines
Video signal-to-noise ratio	better than 40 dB
Audio frequency response	50 Hz–10 kHz
Audio signal-to-noise ratio	better than 43 dB
Tape speed	4.0 cm/sec
Maximum recording time	60 min. (Using a Sony K-60 cassette)
Fast-forward time	3 <sup>1</sup> / <sub>2</sub> min. (K-60)

### Timer

Setting calibrations	every ten minutes, click-stops
----------------------	--------------------------------

Design and specifications are subject to change without notice.

